

AUTOCASE® SC-3

SEMI-AUTOMATIC CASEMAKER

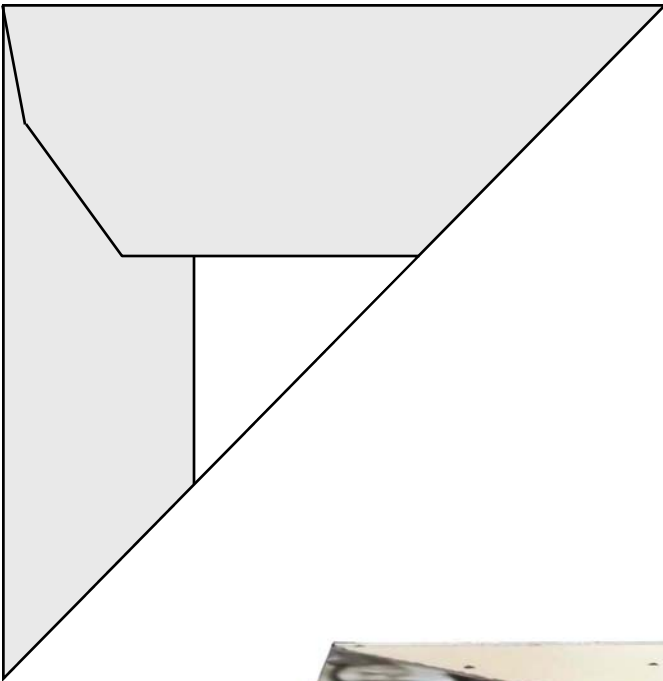

SC-3 AUTOCASE

**ZERO SIZE CHANGE + ZERO SCRAP + QUICK TURNAROUND +
SIMPLE OPERATION = PROFIT ON SHORT RUNS**

► **SIMPLE**

With zero size change the Autocase does not require highly skilled operators or maintenance personnel.

► **RELIABLE**

Our proven technology allows our customers to plan their production, day in and day out.

► **VERSATILE**

Our customers produce virtually every turned edge product type using all types of cover material, boards and adhesives in run counts from one cover to five hundred or more.

► **AFFORDABLE**

The SC-3 Autocase offers superior payback compared to alternative methods of automation or manual production based on cost to purchase, labor savings, zero scrap and reliable production output.

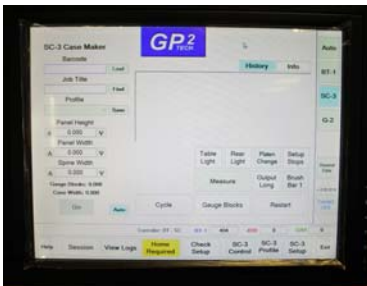

The Operator Interface PC/Touchscreen is representative of the advanced technology built into the Autocase and not found on other entry or mid level bindery equipment. The SC-3 control system further exemplifies our commitment to “user” friendly, simple to operate casemakers. Connectivity to the internet allows for remote diagnostics, access to instructional videos, and fast, accurate support.



The Corner Trimmer Option accurately and automatically trims the Corners from the cover material during the casemaking operation. This feature streamlines production for On-Demand and Ultra Short Run applications while providing high quality, uniform corners on every cover—even in runs of one!



The standard SC-3 is equipped for seamless integration with all Cover-1 System components to provide additional POD hardcover automation. Because of the modular design, you may grow your investment to achieve greater automation and increased efficiency by integrating material preparation and delivery for hardcover runs down to one.

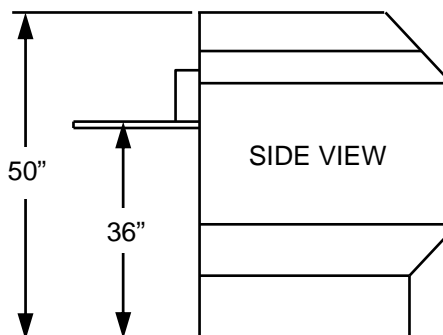
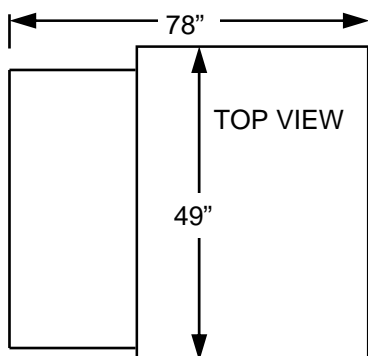

AUTOCASE® SC-3

Semi Automatic Casemaker

Specifications

Operating Speed:

Up to 300 cycles / hour

Make ready time:

Zero

Operators:

One

Operator Interface:

Touchscreen

Case Gage:

Built in

Case Size:

6.62" - 16" Height

*8.62" - 26" Width**

**28" Without Corner Trimmer*

Board Thickness:

.060" – .125"

Padded board up to .25"

Spine Thickness:

up to board thickness

Spine Width:

.25" – 3.25"

Electrical:

230 V, Single phase

50/60 Hz, 6 Amp

Compressed Air:

2cfm @ 80 psi

Machine weight:

Approx. 900 lbs

Specifications are subject to change or revision

Optional Equipment:

Automatic Corner Cutters

Single Board Guide

Automated Side Guide

Automated Gage Arms

Bar Code System for job data

G-2 Gluer

FS-1 Flexible Spine System

BT-1 Board Trimmer

Outfeed Conveyor

GP² Technologies, Inc.

157 River Road, Unit 18

Bow, NH 03304

Sales Tel. 1-802-888-2956

Tel. 603-226-0336

Fax 603-226-0444

Web: www.gp2tech.com

e-mail: sales@gp2tech.com

033016